

Model E300AJP

ARTICULATING BOOM LIFTS



MORE ECONOMIC

- Electric power for zero emissions and near-silent running indoors.

MORE PRODUCTIVE

- No waiting with immediate-response AC drive motors for greater torque and efficiency.

MORE ACCESS

- Access hard-to-reach places with near-vertical jib positioning and 180-degree side-to-side movement.

SMART DESIGN

- Enjoy industry leading upcycles so you can work longer with higher productivity.

Standard Features

- 0.76 m x 1.22 m low mount platform
- Side entry with drop bar mid rail
- Multiple function operation
- Full proportional drive joystick control with integral thumb steer switch
- Full proportional main boom and swing joystick control
- Multiple speed control for lower boom, telescope, jib and platform rotate
- Selectable creep speed on drive / lift and swing functions
- 1.22 m articulating jib
- JibPLUS® with 4 way axis 1.22m Jib
- 180 degree powered platform rotator
- Platform console machine status light panel ¹
- Load sensing system
- AC power cable to platform
- Two Wheel Direct Electric Drive
- Automatic traction control
- Programmable "Personality" settings
- On-board self-diagnostic testing
- Enclosed battery / electrical compartment
- 20 amp automatic battery charger
- Automatic rear wheel brakes
- Sculptured ABS hoods
- 3 degree tilt alarm and indicator light
- 1.22m narrow frame
- Lifting/tie down lugs
- Ground control selector switch with key lock
- Battery condition indicator
- Hour meter
- Horn
- Manual descent system
- Platform tool tray
- JLG Skyguard active system

¹ Provides indicator lights at platform control console for system distress, low battery, tilt light, and foot switch status.



Standard Specifications

Power Source	
• Electrical System	48V AC
• Batteries - deep cycle	8 x 6V 305 A/hr
• Drive Motors	Dual AC Traction
Hydraulic System	
• Hydraulic Motor	Perm. Magnet
Tyres	25 x 7-12 Non marking

Accessories & Options

- Self closing inward swing gate
- 8 x 6V, 370 A/hr Batteries
- All motion alarm
- 305 A/hr AGM Batteries
- Alarm package ²
- Platform worklights
- Amber strobe light
- Euro Plug & Socket
- Acrylic console shield
- Cylinder bellows
- Skyguard beacon (ILOS)
- Synthetic Biodegradable Hydraulic Oil
- Programmable Security Lock
- Special paint colour

² Includes all-motion alarm and amber strobe light.

Model E300AJP

ARTICULATING BOOM LIFTS

Performance

• Working Height	10.97 m
• Working Outreach	6.77 m
• Up and Over Height	4.01 m
• Swing (non-continuous)	350°
• Platform Capacity – Unrestricted	230 kg
• Platform Rotator (Hydraulic)	180°
• Jib – Overall Length	1.22 m
• Jib – Range of articulation	144° Vertical (+84°/-60°)
A. Platform Size	0.76 m x 1.22 m
B. Overall Width	1.22 m
C. Tailswing (working condition)	Zero
D. Stowed Height	2.01 m
E. Stowed Length	5.74 m
F. Wheelbase	1.65 m
G. Ground Clearance	0.10 m
• Machine weight ¹	7,100 kg
• Maximum Ground Bearing Pressure	11.95 kg/cm ²
• Drive Speed	7.2 km/h
• Gradeability	25%
• Turning Radius – Inside	1.52 m
• Turning Radius – Outside	3.10 m

¹ Certain options or country standards may increase weight and/or dimensions.



Reach Diagram

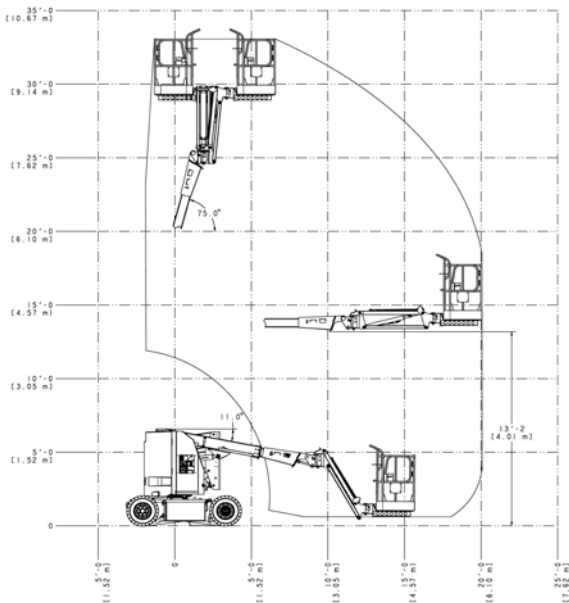

Dimensions

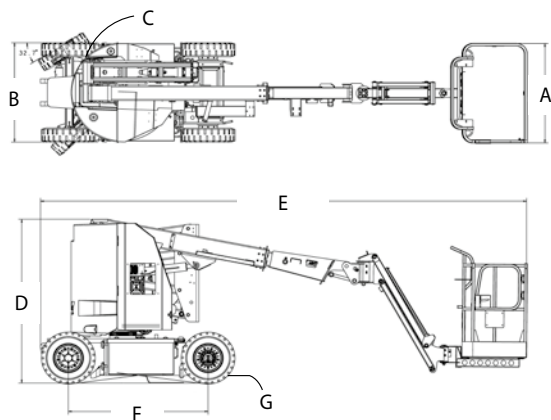

IMPORTANT

JLG is continually researching and developing products and reserves the right to make modifications without prior notice. All data in this document is indicative. Certain options or country standards will increase weight. Specifications may change to meet country standards or with the addition of optional equipment.

Due to continuous product improvements, JLG Industries reserves the right to make specification and/or equipment changes without prior notification.



JLG EMEA BV

Polaris Avenue 63
2132 JH Hoofddorp
The Netherlands
Phone: +31 (0)23 565 5665
www.jlg.com

An Oshkosh Corporation Company