

Model 1250AJP

ARTICULATING BOOM LIFTS



MORE ECONOMIC

- Lower hydrocarbon, carbon monoxide, particulate and NOx emissions with Stage V-compliant engine.

MORE PRODUCTIVE

- Equipped with hydrostatic drive for easy, precise, infinitely-variable-speed manoeuvrability. Go from ground to over 40m in under 115 seconds and enjoy industry best reach envelope with exclusive QuikStik® boom.

MORE ACCESS

- Conquer rough terrain with standard oscillating axle and four-wheel drive, delivering optimised grip and stability.

SMART DESIGN

- Customer-preferred controls mean fewer buttons and switches used to position the platform and less time spent learning to use the platform controls.

Standard Features

- 0.91 m x 2.44 m low mount platform
- Side entry with drop bar mid rail
- Multiple function operation
- Full proportional drive joystick control with integral thumb steer switch
- Full proportional main boom and swing joystick control
- Variable speed dial control for telescope, platform rotate and tower
- 2.44 m articulating jib
- JibPLUS® with 4 way axis jib including 125 degree horizontal motion
- Powered side stow on jib
- 180 degree powered platform rotator
- Platform console machine status light panel¹
- Load sensing system
- AC power cable to platform
- Gull-wing turntable hoods
- Swing-out engine tray
- Spark arresting type muffler
- Control ADE® - (Advanced Design Electronics System)
- Adjustable swing drive
- Hydrostatic transmission
- Four wheel drive
- Four wheel steer/Two Wheel Steer/ Crab Steer
- Horn
- Selectable dual platform capacity system (230kg/450kg)
- QuikStik® boom design feature
- Drive-out extending axles
- 5 degree tilt alarm and indicator light
- Oscillating front axle
- Lifting/tie down lugs
- On-board 4,000W generator
- Hour Meter
- Ground control selector switch with key lock
- Load Sensing Hydraulics
- Catalytic Purifier Muffler
- 12V-DC auxiliary power

Standard Specifications

- | | |
|----------------------|---------------------------------|
| • Diesel Engine | Deutz TCD2.9 L4 (74hp, 55.4 kW) |
| • Fuel Tank Capacity | 117 L |
| • Hydraulic System | 390 L |
| • Auxiliary Power | 12V DC |
| • Tyres | 445/50D710 Foam Filled |

Accessories & Options

- 0.91 m x 1.83 m low mount platform
- 0.76 m x 0.91 m low mount platform, rear entry⁶
- Tri entry 0.91 m x 1.83 m low mount platform
- Side entry with inward swing gate
- 13 mm air line to platform
- Engine distress warning system²
- On-board 4,000W generator
- SkyGlazier® package glass and panel tray
- Nite-Bright® package³
- All motion alarm
- Light package⁴
- Platform worklights
- Head and tail lights
- Flashing amber beacon
- Plugs and sockets
- Hostile environment package⁵
- Hydraulic oil cooler
- Skyguard with beacon
- Skyguard without beacon
- Soft Touch Proximity System
- Corner Storage tray
- ClearSky Locate
- ClearSky CAN



¹ Provides indicator lights at platform control console for system distress, low fuel, 5 degree tilt light, and foot switch status.

² Low oil pressure and high coolant temperature alarms with shut-down enabled/disabled by analyser.

³ Consists of six 40-watt lights, four turntable mounted lights and two platform mounted lights.

⁴ Includes platform mounted work lights and head & tail lights.

⁵ Includes console cover, boom wipers and cylinder bellows.

⁶ Available only with drop bar type entry

Model 1250AJP

ARTICULATING BOOM LIFTS

Performance

• Working Height	40.30 m
• Platform Height	38.30 m
• Horizontal Outreach	19.25 m
• Working Outreach **	19.90 m
• Up and Over Height	18.44 m
• Swing	360° (Continuous)
• Platform Capacity (Restricted)	450 kg
• Platform Capacity (Unrestricted)	230 kg
• Platform Rotator (Hydraulic)	180°
• Jib - Overall Length	2.44 m
• Jib - Range of articulation	130° Vertical (+75°/-55°)
• JibPLUS® - Range of Articulation	125° Horizontal
A. Platform Size	0.91 m x 2.44 m
B ¹ . Overall Width (Axles Retracted)	2.49 m
B ² . Overall Width (Axles Extended)	3.81 m
C. Tailswing (working condition)	0.91 m
D. Stowed Height	3.05 m
E. Stowed Length	11.46 m (transport position)
F. Wheelbase	3.81 m
G. Ground Clearance	0.30 m
• Machine weight *	21,000 kg
• Maximum Ground Bearing Pressure	7.03 kg/cm ²
• Drive Speed 2WD	5.2 km/h
• Drive Speed 4WD	5.2 km/h
• Gradeability 2WD	45%
• Gradeability 4WD	45%
• Axle Oscillation	0.30 m
• Turning Radius – Inside	4.39 m (Axles Retracted) 2.44 m (Axles Extended)
• Turning Radius – Outside	6.86 m (Axles Retracted) 5.89 m (Axles Extended)



* Certain options or country standards may increase weight and/or dimensions.
** Incl. 0.65 m outreach beyond platform

Reach Diagram

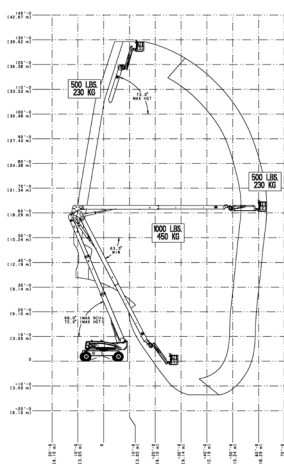

Dimensions

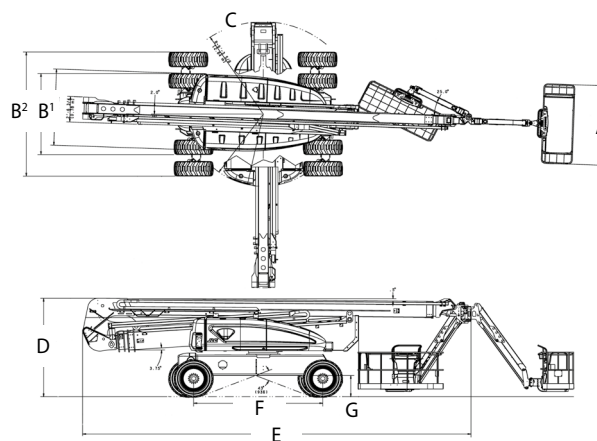

IMPORTANT

JLG is continually researching and developing products and reserves the right to make modifications without prior notice. All data in this document is indicative. Certain options or country standards will increase weight. Specifications may change to meet country standards or with the addition of optional equipment.

Due to continuous product improvements, JLG Industries reserves the right to make specification and/or equipment changes without prior notification.



JLG EMEA BV

Polaris Avenue 63
2132 JH Hoofddorp
The Netherlands
Tel.: +31 (0)23 565 5665
www.jlg.com

An Oshkosh Corporation Company